

EUROSTYLE COSMOPOLITAN

Wastafelmengkraan

S-Size

MODEL # 23387

GROHE nv - sa | Diependaalweg 4a | 3020 Winksele
Tel: +32 (0) 16 23 06 60 | Fax: +32 (0) 16 23 90 70
Mail: info.be@grohe.com

Pure Freude
an Wasser

GROHE

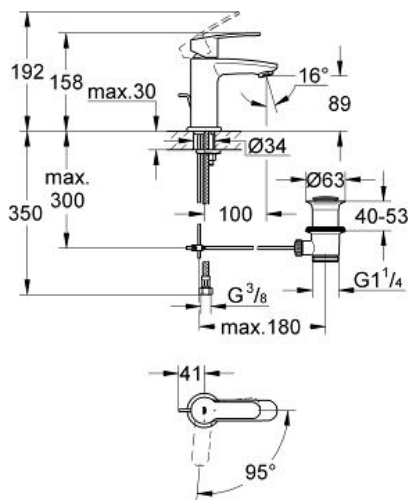

Product Description:

Wastafelmengkraan

S-Size

Standard Specification:

ééngatsmontage

metalen hendel

GROHE SilkMove® ES: energiebesparend dankzij 28 mm cartouche met centrale opening van koud water

GROHE StarLight® schitterende chroomafwerking

GROHE EcoJoy®: waterbesparende mousseur, 5,7 l/min.

GROHE QuickFix® snelle en eenvoudige montage

automatische lediging 1 1/4"

flexibele aansluitslangen

Color:

□ 23387 20E chrom