

(D) Vor Montage bitte Gebrauchsanleitung lesen!

(GB) Please read the instructions of use prior to starting installation work!

(F) Prière de lire le mode d'emploi avant de procéder au montage !

(NL) Lees voor de montage de gebruiksaanwijzing door

(S) Läs igenom bruksanvisningen innan du monterar!

(FIN) Lue käyttöohje ennen asennusta.

(RUS) Перед монтажом прочитайте, пожалуйста, руководство по применению!

(PL) Przed przystąpieniem do montażu przeczytaj instrukcję użytkownika!

(EST) Enne montaaži palun lugeda kasutusjuhendit!

(LT) Prieš montavimą perskaitykite naudojimo instrukciją!

(LV) Pirms ierīces uzstādīšanas, lūdzu, izlasiet lietošanas instrukciju!

(DEN) Læs brugsanvisningen inden montering!

(N) Vennligst les bruksanvisningen før montasjen

(TR) Montaj işleminden önce lütfen kullaným talimatýný okuyunuz!

(I) Prima del montaggio leggere per favore le istruzioni per l'uso!

(E) Lea las instrucciones de uso antes de proceder al montaje!

(GR) Πριν από τη συναρμολόγηση παρακαλούμε να διαβάσετε τις οδηγίες χρήσης!

(H) Kérjük, szerelés előtt olvassa el a használati útmutatót!

# FSTT

1

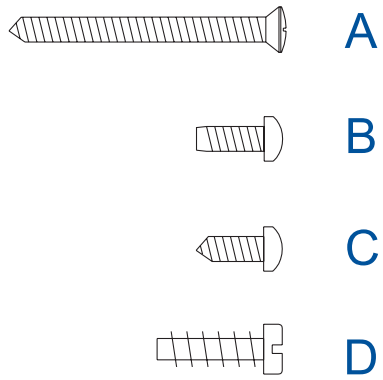

2

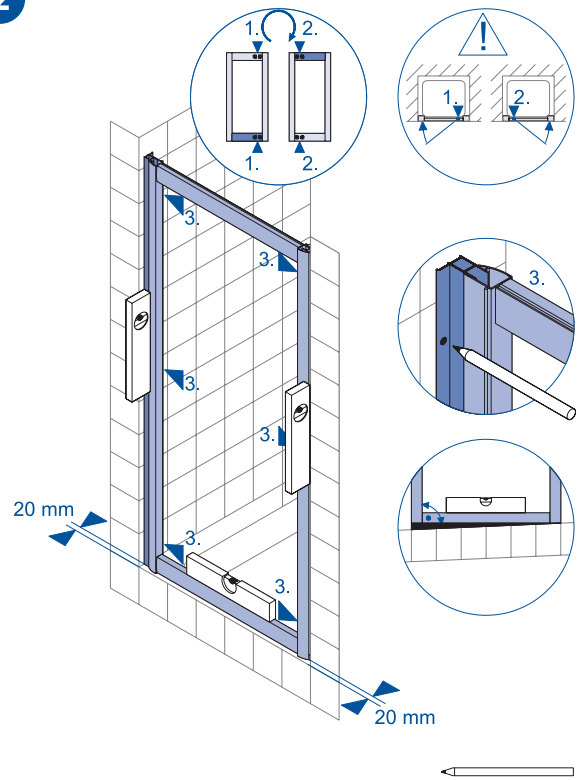

# FSTT/TD

1

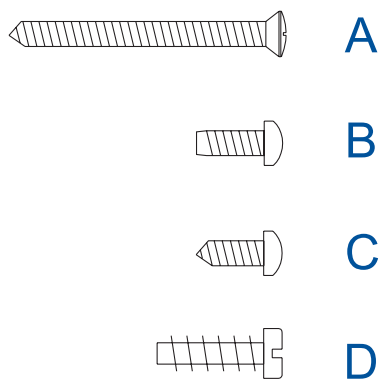

2

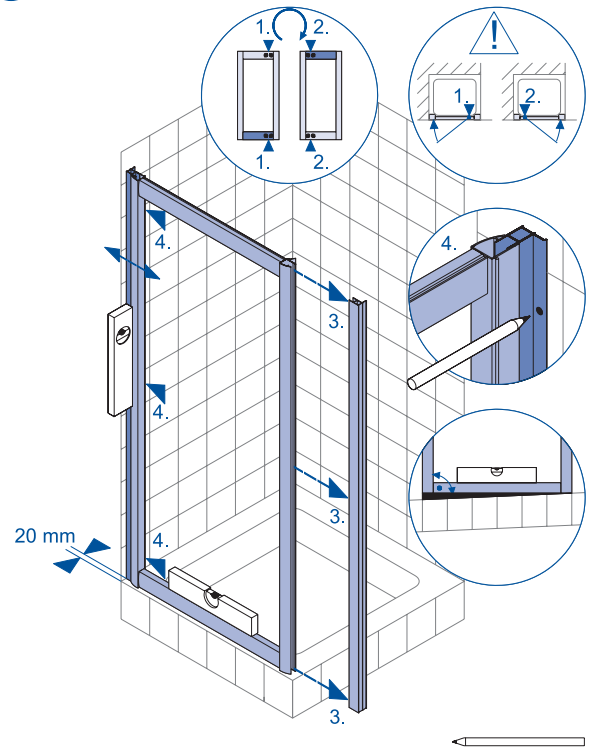

3

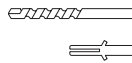
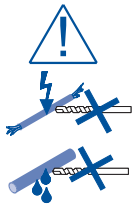
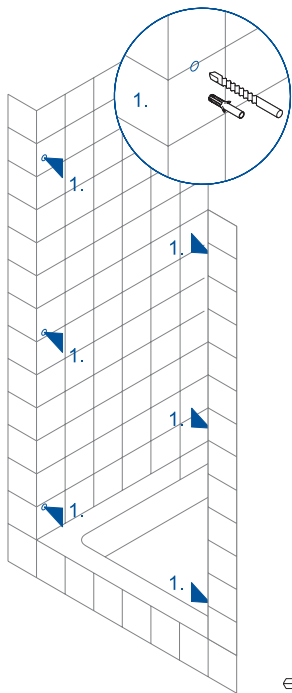

4

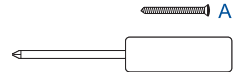
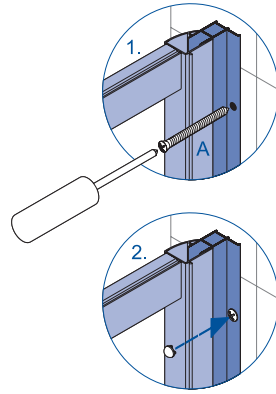
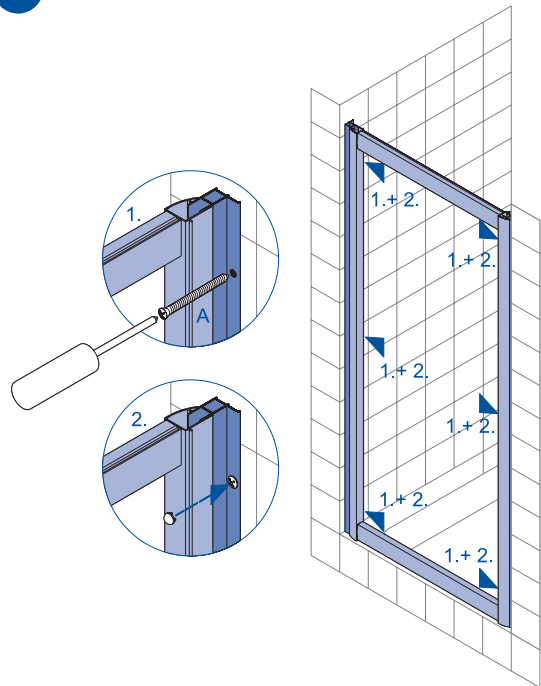

3

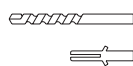
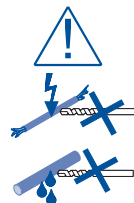
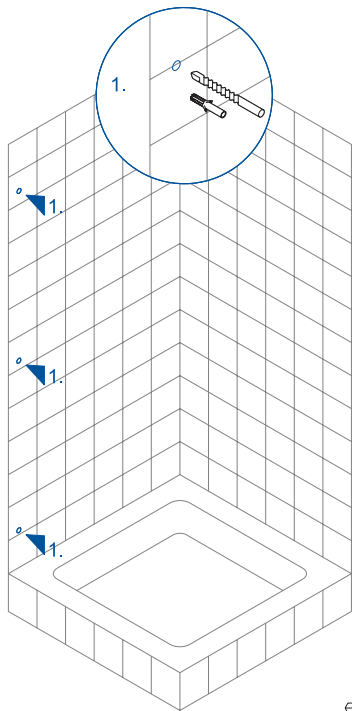

4

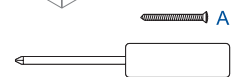
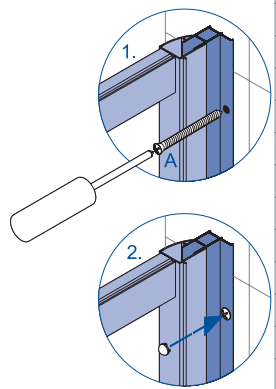
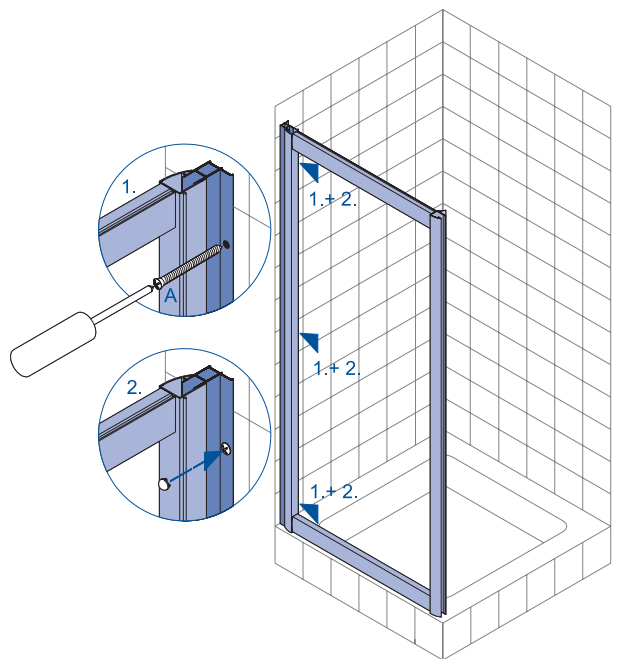

5

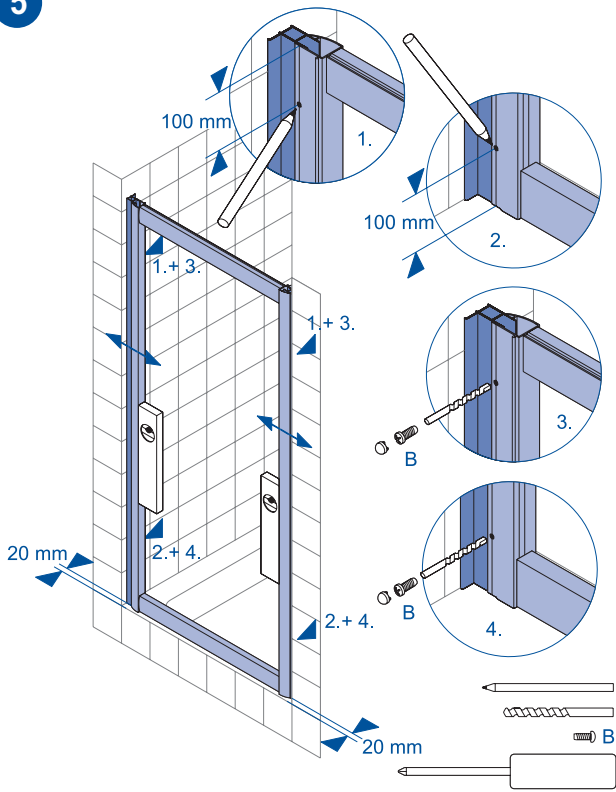

6

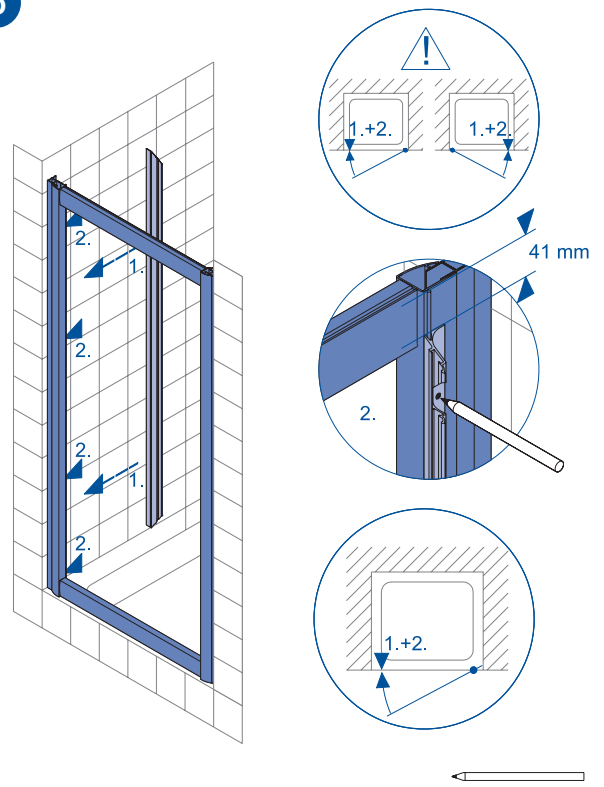

5

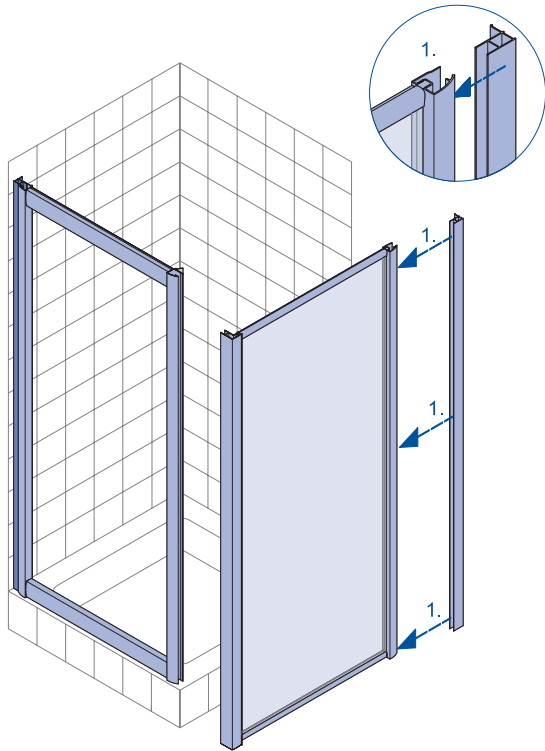

6

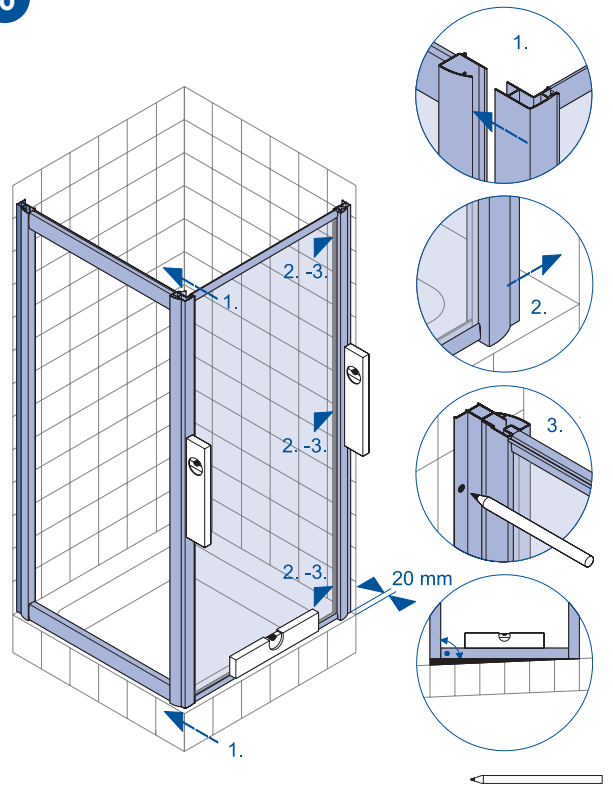

7

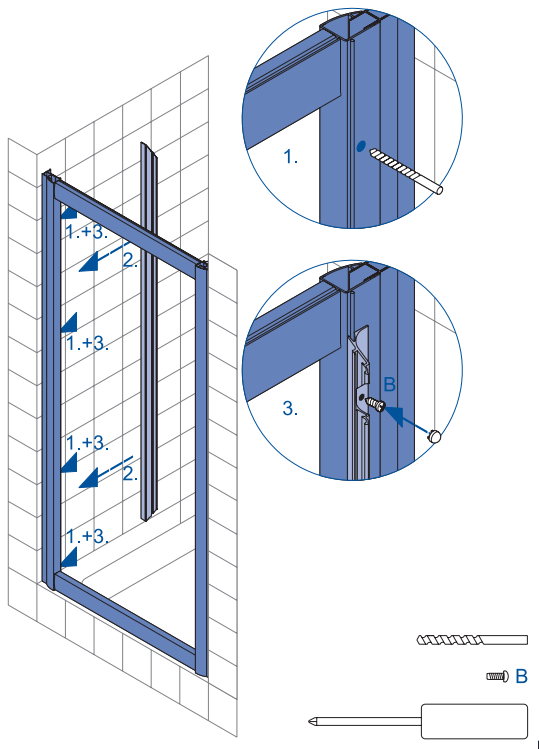

8

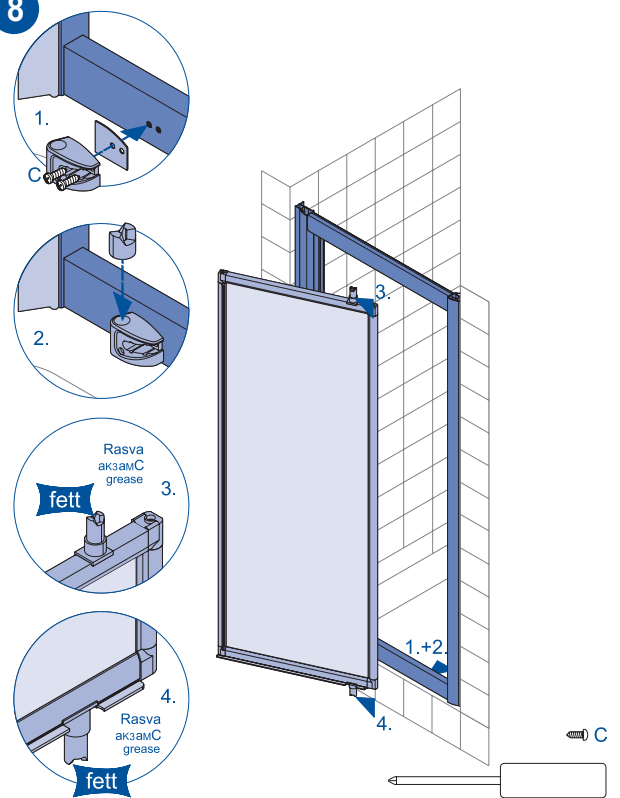

7

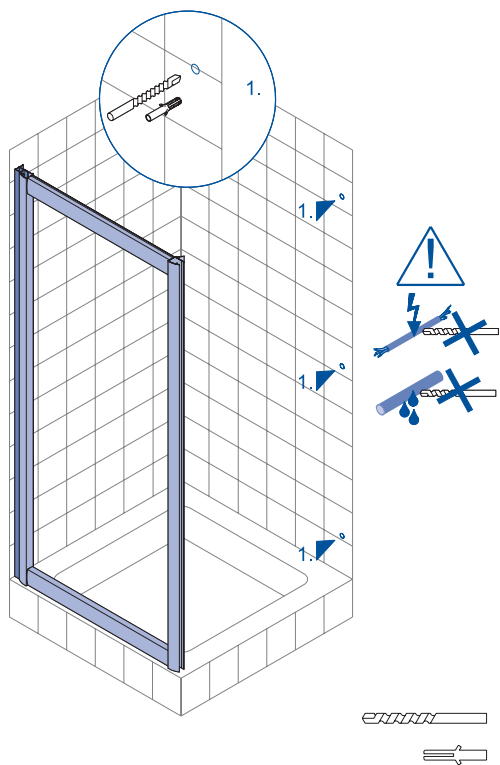

8

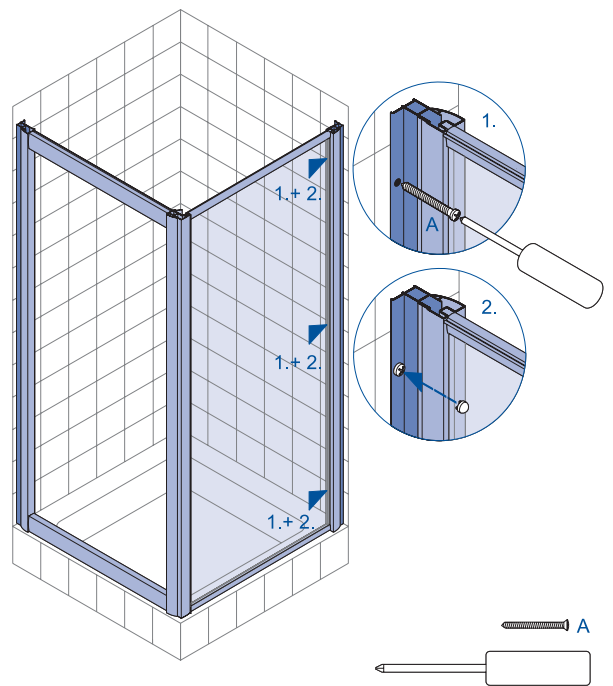

9

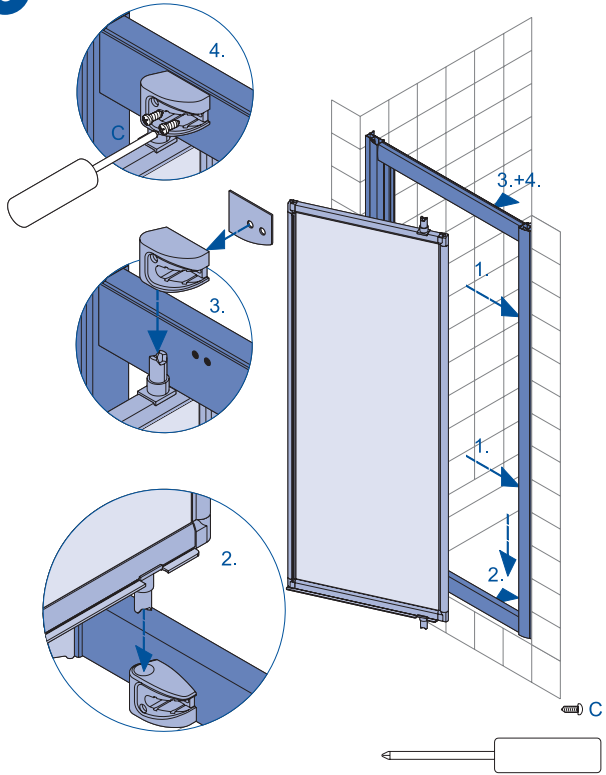

10

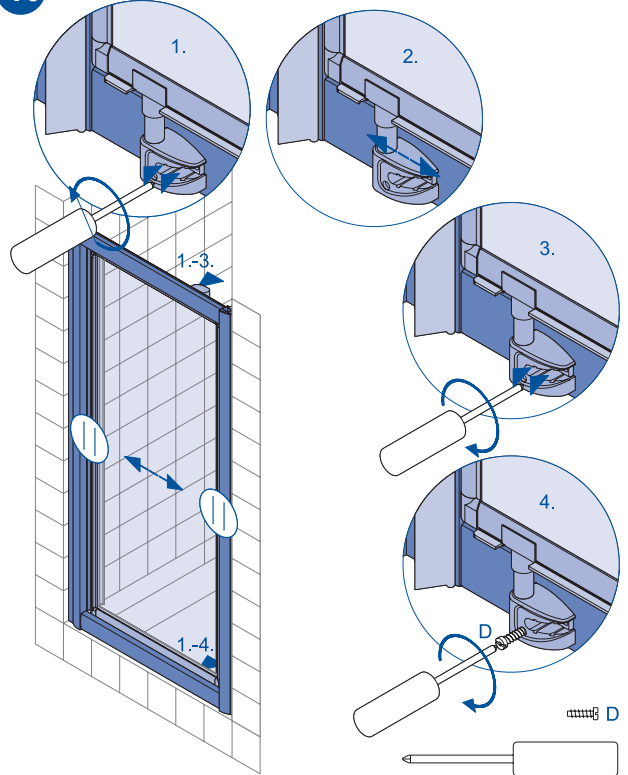

9

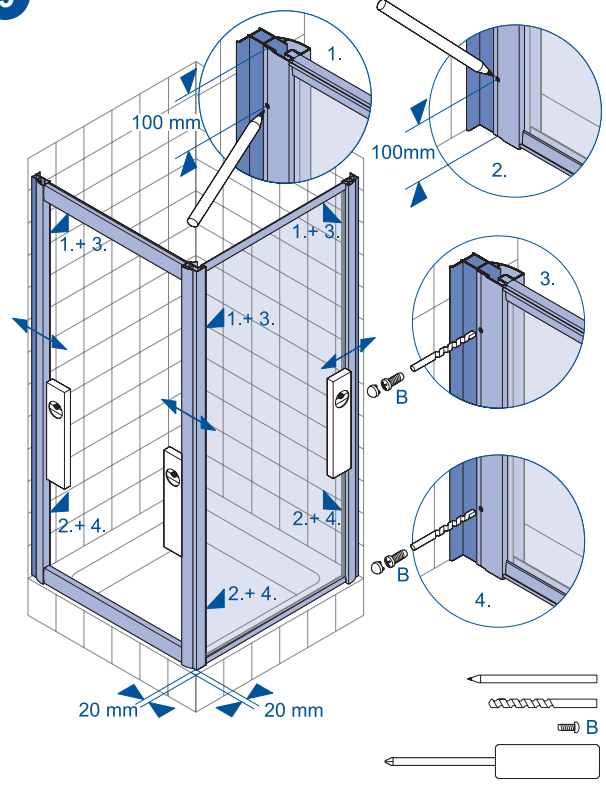

10

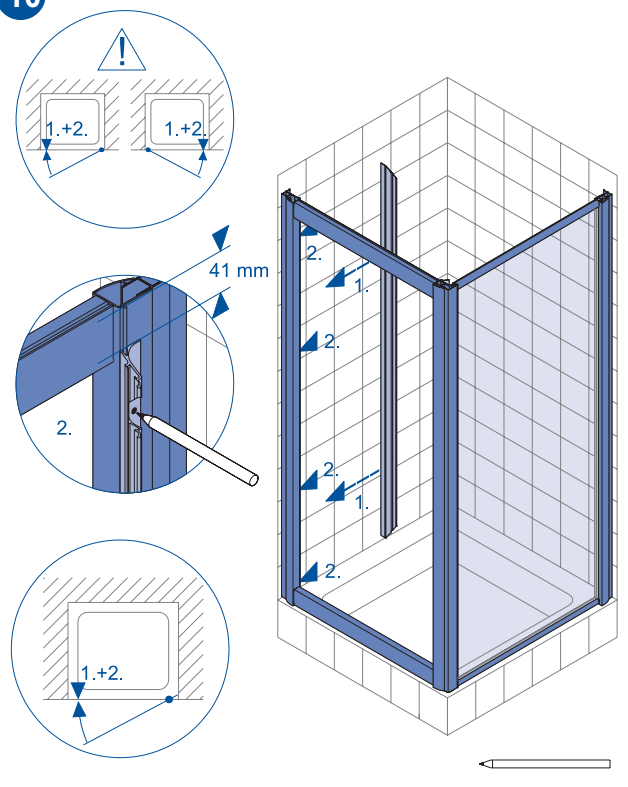

# FSTT

11

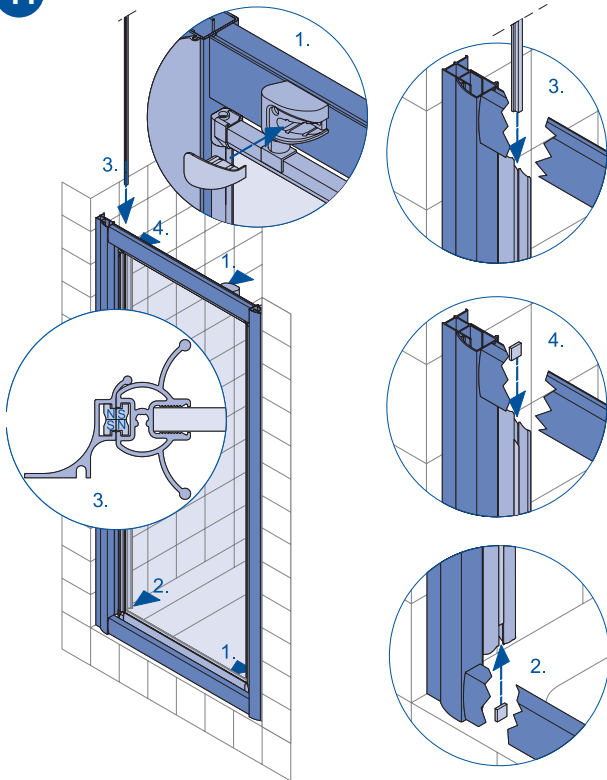

12

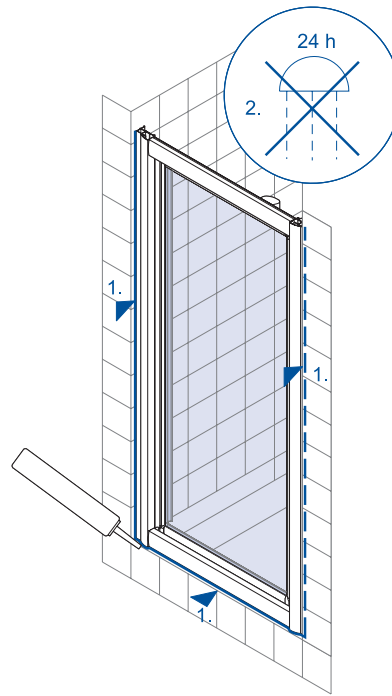

# FSTT/TD

11

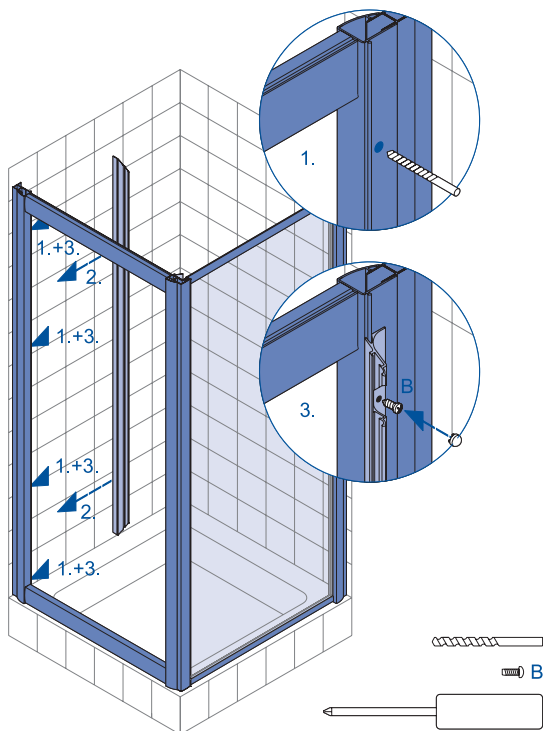

12

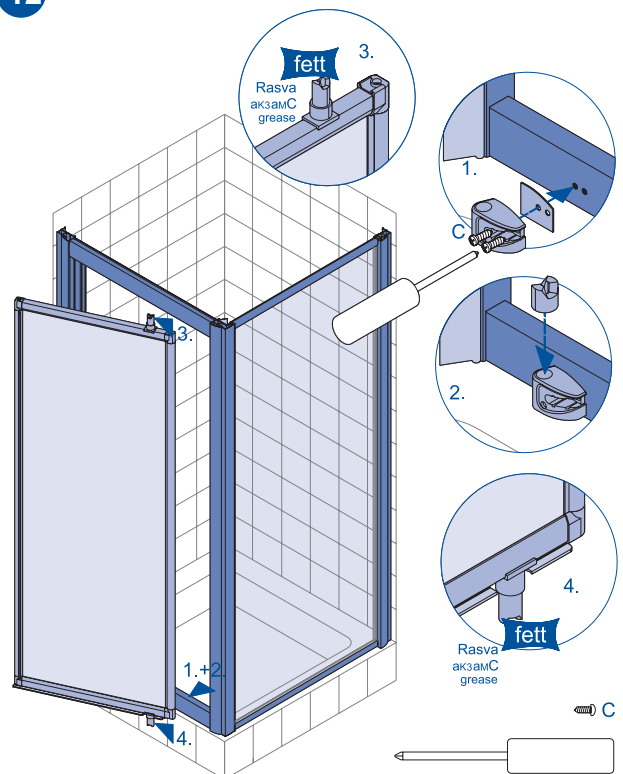

13

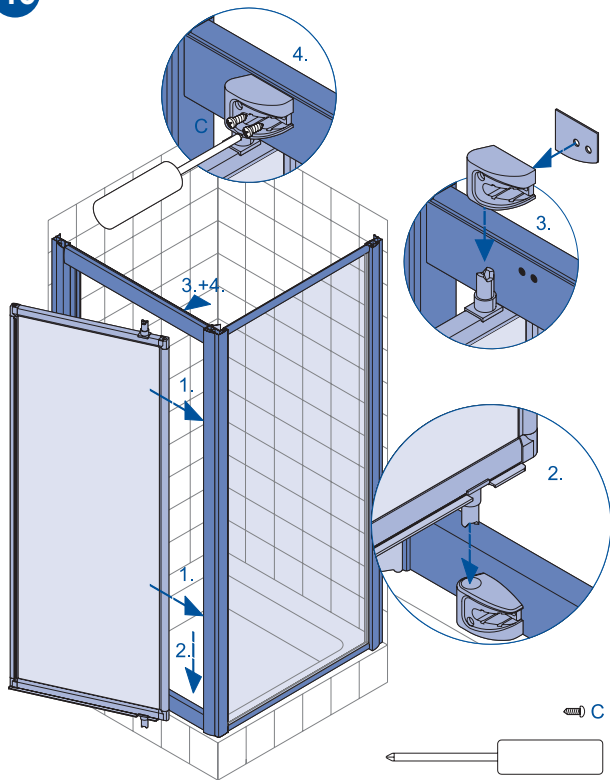

14

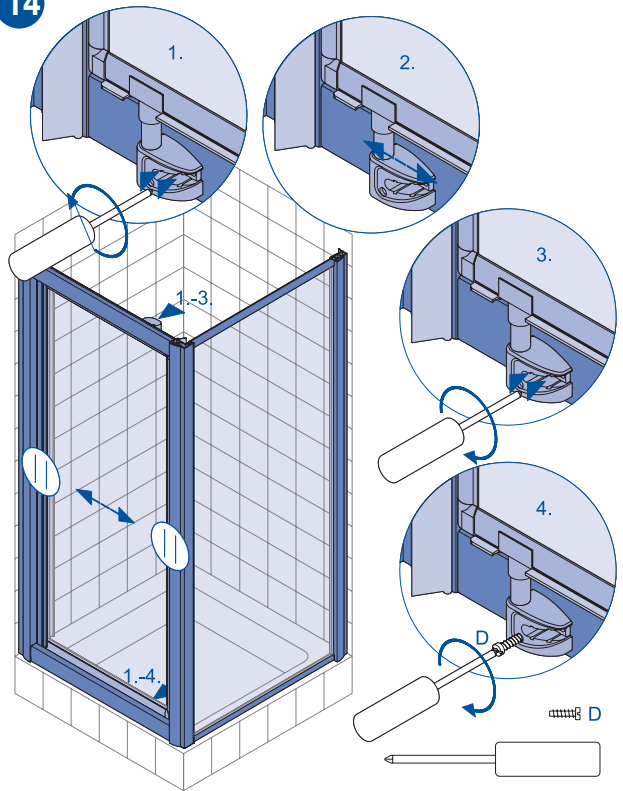

15

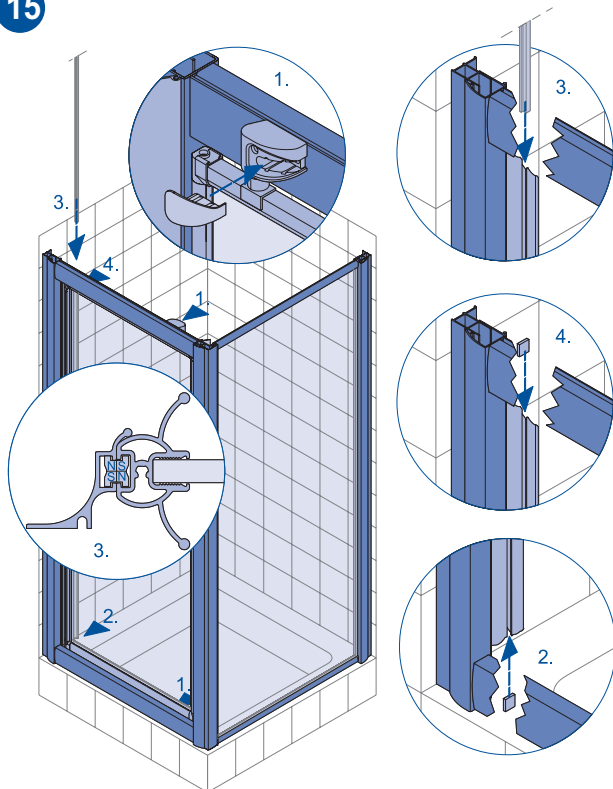

16

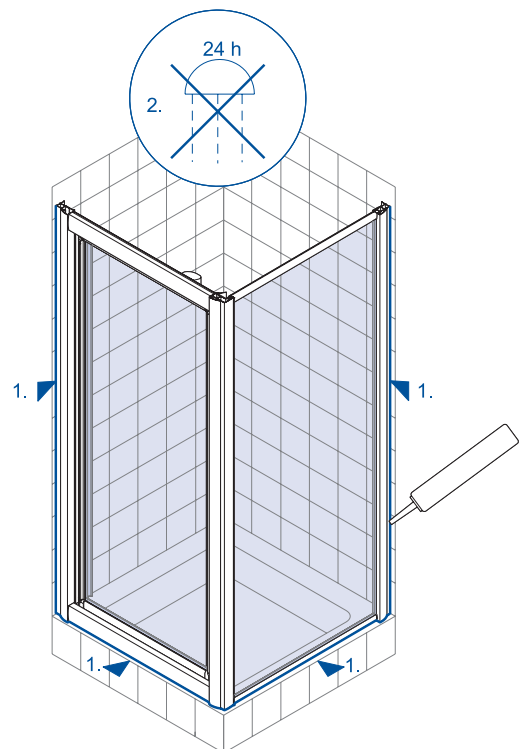



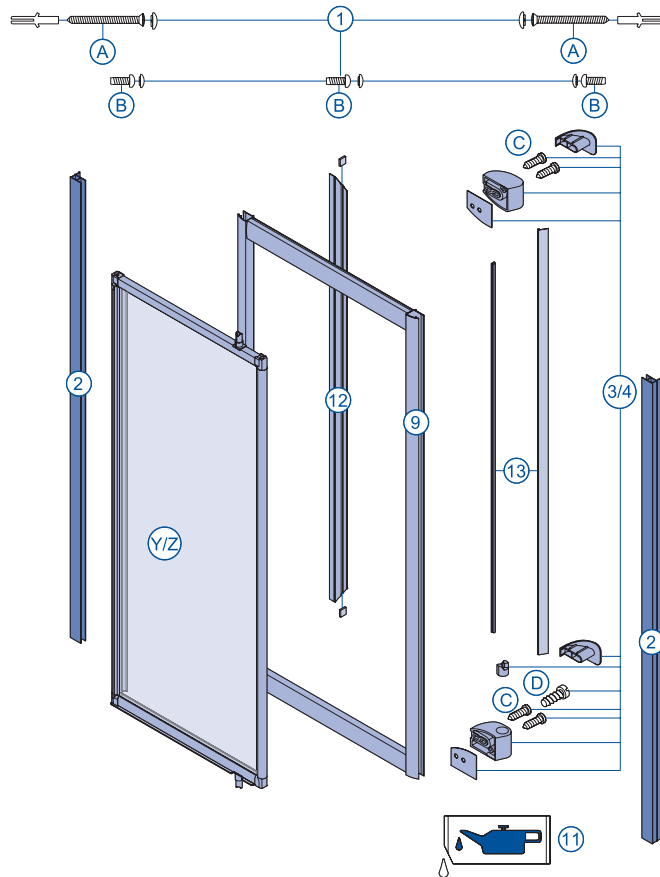

FSTT

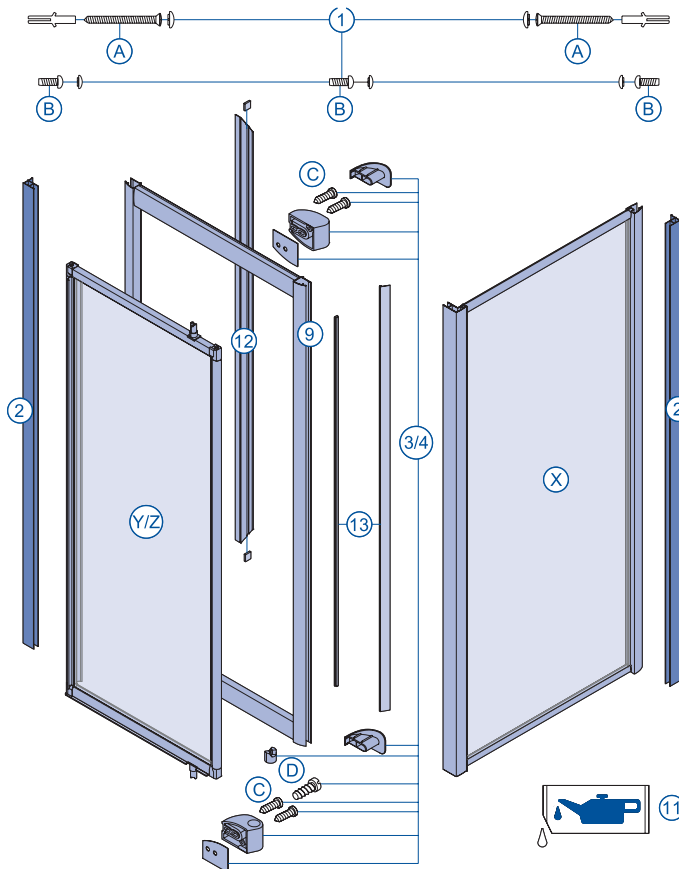

FSTT/TD



 PIN: 0000  
 123456789012345678  
 123456789012 ⇒ Ersatzteil / spare part / Pièce de rechange / Onderdeel / Reservdel / Varaosa / Запасная деталь /  
 Część zamienna / Varuosa / Atsarginé dalis / Rezerves daļa / Reservdel / Reservdel /  
 Yedek parça / Parte di ricambio / Pieza de recambio / Ανταλλακτικό / Ρόταλατρήζ

Vi förbehåller oss rätten till tekniska ändringar för tryckfel eller tekniska förväxlingar påtagar vi oss inget ansvar.

Technische Veränderungen vorbehalten. Voor drukfouten en technische vergissingen stellen wij ons niet aansprakelijk.

Nous nous réservons le droit de procéder à des modifications techniques. Nous n'assurons pas de responsabilité pour des erreurs techniques ou des fautes d'impression.

Technische Änderungen behalten wir uns vor. Für Druckfehler oder technische Verwechslungen übernehmen wir keine Gewähr.