

Standard type

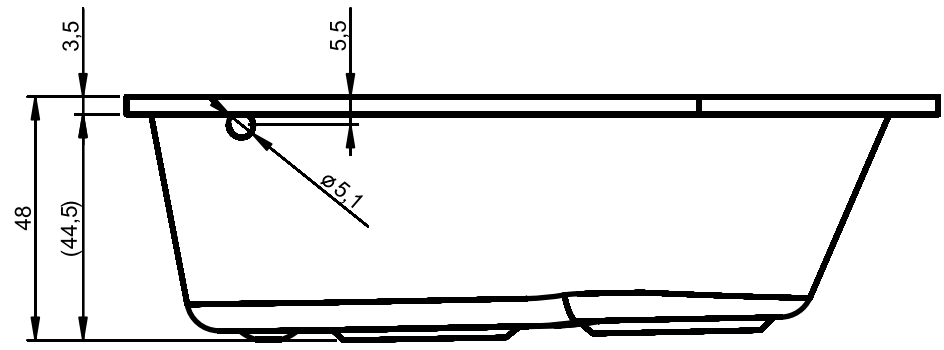

Motor aero in double system (Hydro/Aero)  
Motor aero v kombinovaném systému (Hydro/Aero)

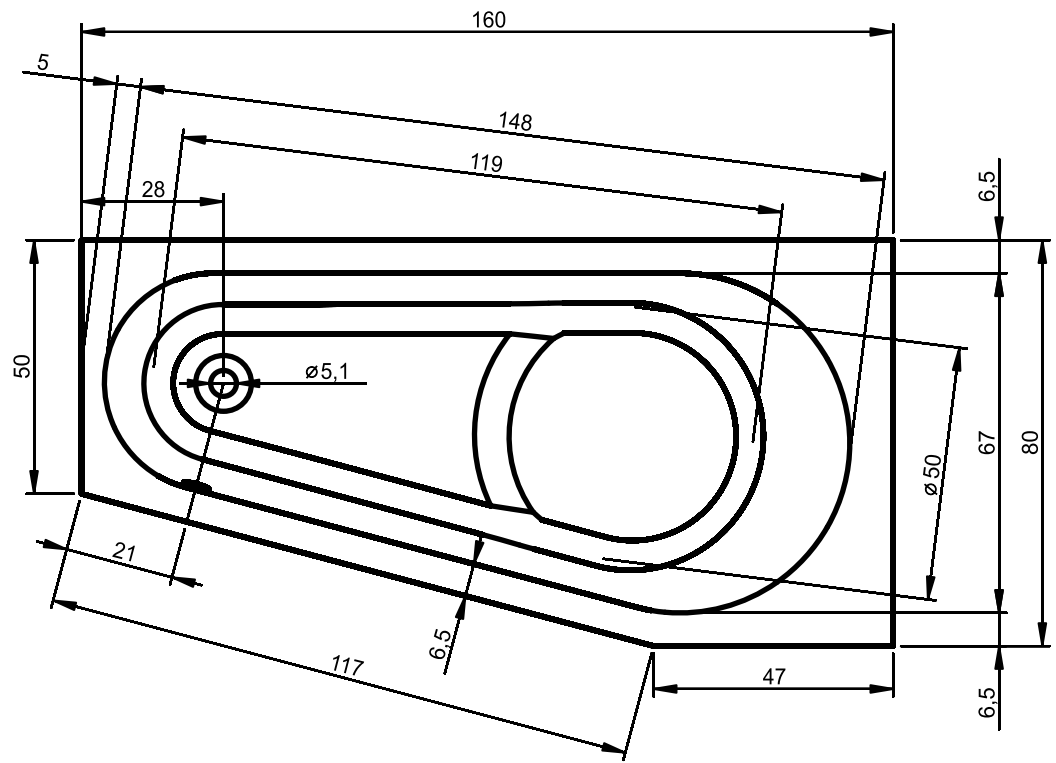
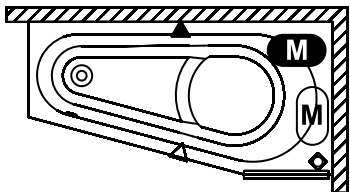

Motor of single system (Hydro or Aero) or hydro motor in double system (Hydro/Aero)  
Motor jednoduchého systému (Hydro nebo Aero) nebo motor hydro v kombinovaném systému (Hydro/Aero)



Pneumatic control or cleanpool (combination of pneumatic control and cleanpool is not possible)  
Mechanické ovládání nebo čistění (kombinace mechanického ovládání a čistění není možná)



Electronic control / Elektronické ovládání



LCD electronic control / LCD elektronické ovládání

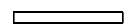

Inspection hatches / Servisní otvor

**HEATER / PŘÍHŘEV** Possible / Lze

Created drawings of systems / Vyhotovené výkresy systémů: E13L, E13T, E16L, E16T, P16L, E46R, P46L, E5ML, E5MT, E5PL, E5PT, P5PL.

Treatment:											
Material:											
Rev	Change no	Dev	Date	Rev	Change no	Dev	Date	Rev	Change no	Dev	Date
A				C				E			
B				D				F			
Scale: 1:15   Format: A4   Unit: cm   Sheet: 1 of 1   Tolerance: NEN-ISO 2768-1 class v											
Name: Delta 160x80 Left										 Third angle	
Linedrawing											
TILBURG HOLLAND Tel: 0031135728728 Fax: 0031135720262			Drawn: LH			Date: 4-9-2007			Project no. 10.324		
			Introduced by tech. change: 72/2007			Draw.no.:			BB830000		
			Article nr.:								