

**Collectieve RVS muurwasgoot voor 2 gebruikers  
voorzien van rugwand, inclusief voorgemonteerde  
leidingen en verchromde hartmengkranen**

1200 mm x 490 mm x 430 mm

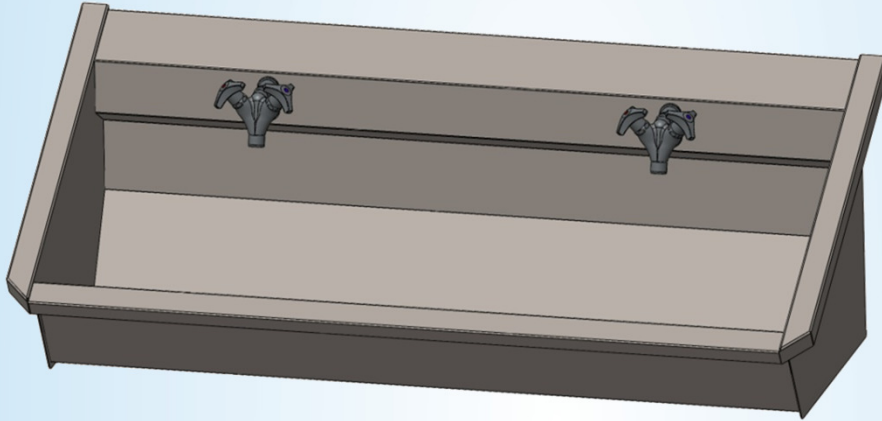

**1.0-2-M5**

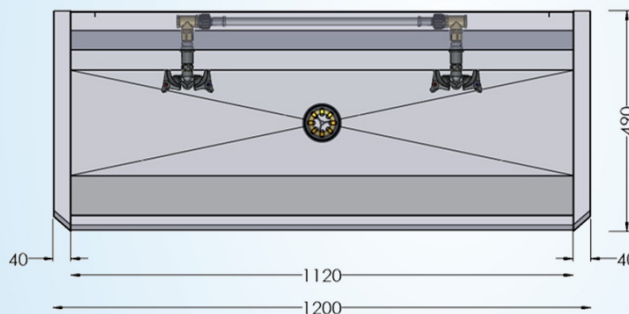
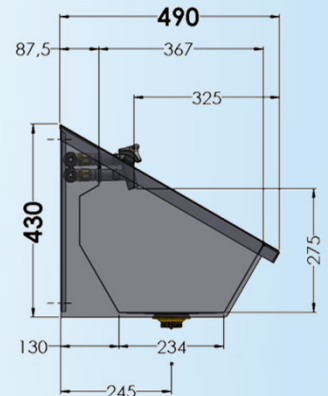
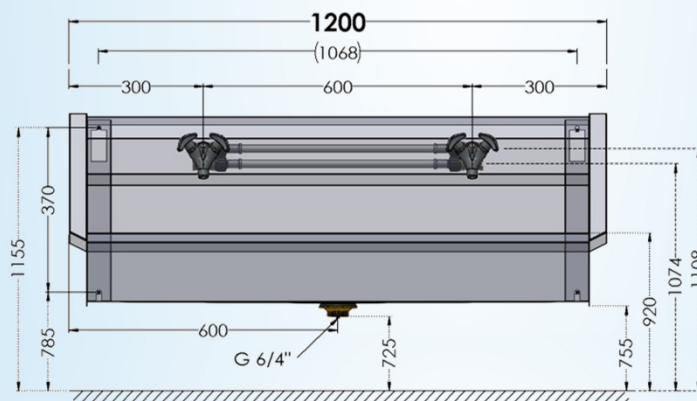

Logistieke gegevens :

gewicht  
1 colli

netto: 14,296 kg

bruto: 16,296 kg

**Sanilav®**

Technische Fiche

## Montage-instructies – Instructions de montage Mounting Instructions – Montage Anleitung

<p><b>A</b> Bevestigingsgaten - Trous de fixation Fixation – Befestigung</p>	<p><b>B</b> Na te meten – A mesurer To measure - Nachmessen</p>

## Aansluitingschema – Instructions de raccordement Water connection Instructions – Wasseranschluss Anleitung

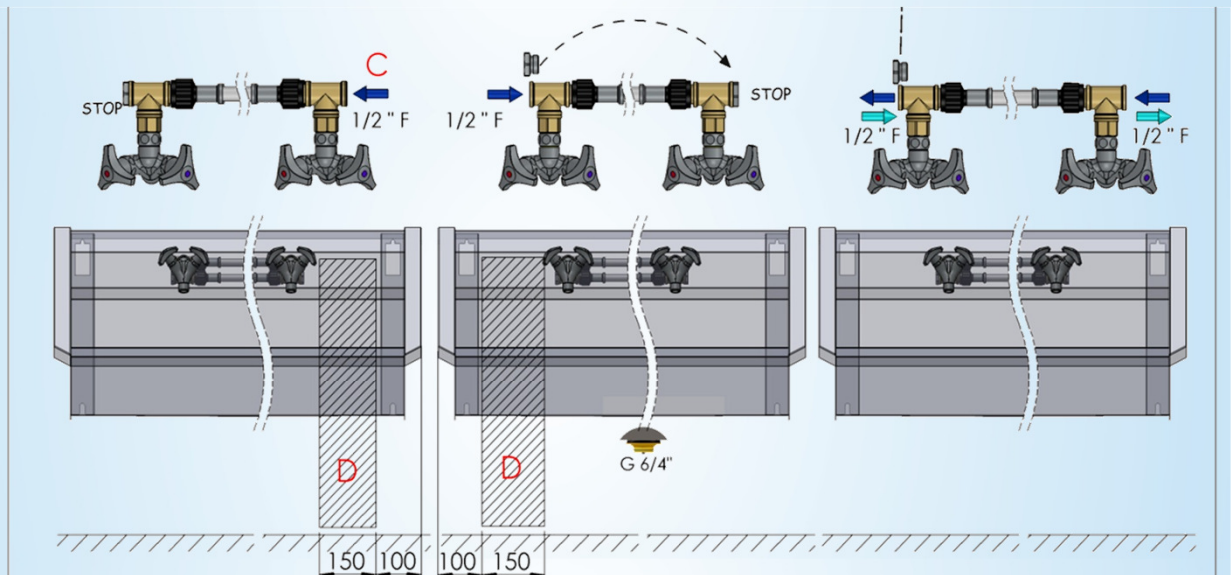

**D** : ZONE WATERAANSLUITING / ZONE RACCORDEMENT D'EAU / WATER CONNECTION ZONE / WASSERANSCHLUSSZONE

Intersan adviseert om een filter te monteren vóór de wateraansluiting (C) van elke wasgoot .  
Intersan conseille à monter un filtre avant le raccordement d'eau (C) de chaque lavabo rigole .  
Intersan advises to install a filter before the water connection (C) of every wash trough .  
Intersan empfiehlt einen Filter zu installieren vor jedem Wasseranschluss (C) jeder Waschrinnen .