

# EUROSMART COSMOPOLITAN

## Wastafelmengkraan

### M-Size

MODEL # 23325000

GROHE nv - sa | Diependaalweg 4a | 3020 Winksele  
Tel: +32 (0) 16 23 06 60 | Fax: +32 (0) 16 23 90 70  
Mail: info.be@grohe.com

Pure Freude  
an Wasser

**GROHE**

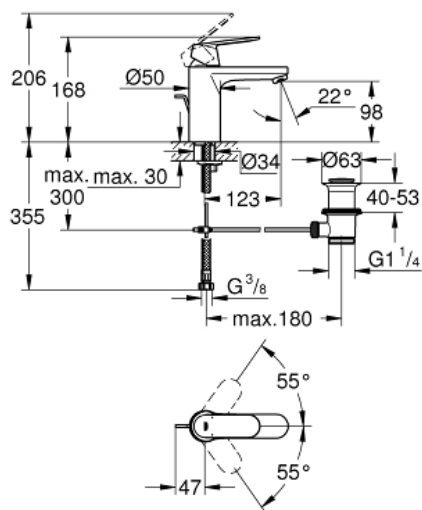

#### Product Description:

##### Wastafelmengkraan

##### M-Size

#### Standard Specification:

ééngatsmontage

metalen hendel

**GROHE SilkMove** 35 mm cartouche

met keramische schijven

variabel instelbare debietbegrenzer

**GROHE StarLight** schitterende chroomafwerking

**GROHE EcoJoy**: waterbesparende mousseur, 5,7 l/min

**GROHE QuickFix** snelle en eenvoudige montage

automatische lediging 1 1/4"

flexibele aansluitslangen

#### Color:

□ 23325000 chroom